

SOUND-INSULATED FANS

Series
VENTS KSB



Inline centrifugal fans in heat- and sound-insulated casing with the air capacity up to **2150 m³/h** and up to **2150 m³/h**

■ **Applications**

KSB fan design enables its application in supply and exhaust ventilation systems for the premises with high requirements to noise level and limited mounting space. Provision is made for installation in a premise above the suspended ceiling. Suitable for connection with 100, 125, 150, 160, 200, 250 and 315 mm round ducts.

■ **Design**

The fan casing is made of galvanized steel sheet and provided with heat- and sound-insulating material. Round connecting pipes are fitted with rubber seals.

■ **Motor**

The centrifugal impeller with backward curved blades is powered by means of 2-pole asynchronous motor with external rotor. The motors are equipped with built-in thermal overheating protection with automatic restart. Motor ball bearings with selective lubricating oil ensure low-noise and maintenance-free fan operation. KSB...M model motor is installed onto the rubber anti-vibration mounts to reduce vibration and noise. Models marked KSB...S are featured with the high-powered motors.

■ **Speed control**

Smooth or step speed control with a thyristor or autotransformer speed controller. Several fans may be connected to one speed controller provided that the total power and operating current do not exceed the rated speed controller parameters.

■ **Mounting**

The fans are designed for inline mounting inside an air duct of matching air duct diameter, in any point of the ventilation system and at any angle. The fan shall be fixed to a building by means of supports, suspension brackets or fixation brackets in case of flexible connectors application. The fan can be mounted in any position with respect to the air flow direction indicated with a pointer on the fan casing. Access to the fan maintenance shall be provided.

■ **The fan with electronic temperature and control module (U option).**

The ideal solution for ventilation of the premises requiring permanent temperature control, i.e. greenhouses. The fan with the electronic temperature and speed control module provides automatic control of the motor speed (air capacity) depending on air temperature in the air duct or in the room.

The fan front panel has the following control knobs:

- speed control knob for setting the motor speed;
- thermostat control knob for setting the temperature set point;
- thermostat indicator light.

The fan is available in two modifications:

- with the temperature sensor integrated inside the fan air duct (U/U1 option);
- with the external temperature sensor fixed on the cable, 4 m long (Un / U1n).

■ **Control logic of the fan with the electronic temperature and speed control module**

Set the desired air temperature (thermostat set point) by turning the thermostat control knob. Set the required minimum impeller speed (air flow) by turning the speed control knob. The motor switches to maximum speed (maximum air flow) as the temperature reaches and exceeds the set temperature set point. The motor switches to the pre-set lower speed as the temperature drops below the temperature set point. To avoid frequent motor speed switches when the air temperature in the duct is equal to the set temperature point, the speed switch delay is activated. There are two switch delay patterns for various cases:

1. The temperature sensor-based switch delay (U option): the motor switches to higher speed as the air temperature exceeds 2 °C above the set

thermostat set point. The motor reverts to the preset lower speed as the air temperature drops below the thermostat set point. This pattern is used to keep air temperature to within 2 °C. In this case the motor speed switches are rare.

2. The timer-based switch delay (U1 option): as the air temperature exceeds the set thermostat set point, the motor switches to higher speed and the switch delay timer is activated for 5 min. The motor reverts to lower speed as the air temperature drops down below the thermostat set point and only after 5 minutes timer countdown.

This pattern is used for exact air temperature control. The speed switches for the fan with U1 option are more frequent as compared to the operating logic of the fan with U option, however the minimum operating cycle at one speed is 5 minutes.

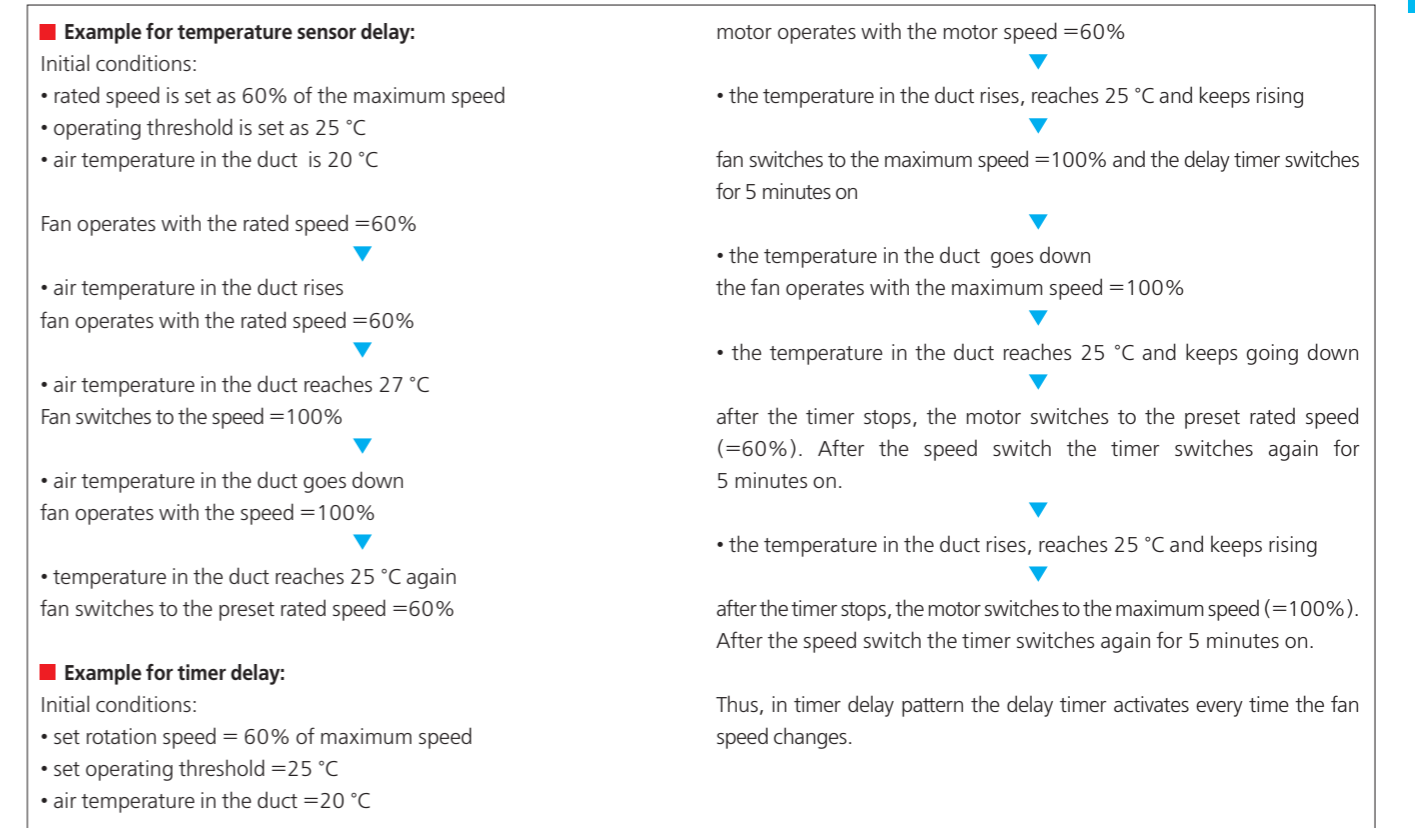

Designation key:

Series	Spigot diameter	Options
VENTS KSB	100; 125; 150; 160; 200; 250; 315	<p>R – power cord with IEC C14 electric plug.</p> <p>S – high-powered motor.</p> <p>M – anti-vibration mount.</p> <p>U – speed controller with electronic thermostat and temperature sensor integrated into the air duct. Equipped with power cord and IEC C14 electric plug. Temperature-based operation logic.</p> <p>Un – speed controller with electronic thermostat and external temperature sensor fixed on 4 m cable. Equipped with power cord and IEC C14 electric plug. Temperature-based operation logic.</p> <p>U1 – speed controller with electronic thermostat and temperature sensor integrated into the air duct. Equipped with power cord and IEC C14 electric plug. Timer-based operation logic.</p> <p>U1n – speed controller with electronic thermostat and external temperature sensor fixed on 4 m cable. Equipped with power cord and IEC C14 electric plug. Timer-based operation logic.</p>

Accessories



page 378 page 386 page 388 page 392 page 406 page 442 page 446 page 461 page 462 page 476 page 477 page 480

Fan overall dimensions:

Type	Dimensions [mm]							Weight [kg]
	∅D	B	B1	H	L	L1	L2	
KSB 100	99	322	280	192	447	380	350	5.4
KSB 125	124	322	280	192	447	380	350	5.4
KSB 150	149	352	310	212	477	410	380	6.4
KSB 160	159	352	310	212	477	410	380	6.4
KSB 200	199	432	368	287	588	506	480	10.0
KSB 200 S	199	432	368	287	588	506	480	12.0
KSB 250	249	432	368	287	588	506	480	12.5
KSB 315	314	502	438	397	648	566	540	15.5

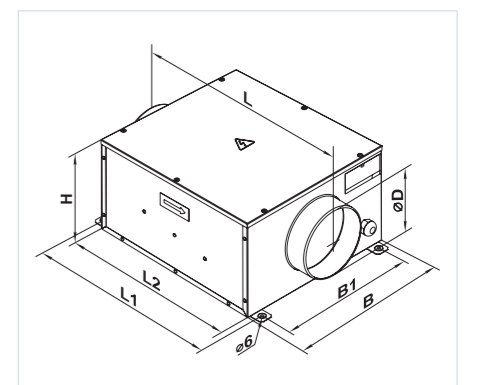

SOUND-INSULATED FANS

Technical data:

	KSB 100		KSB 125		KSB 150		KSB 160	
Voltage [V]	1~ 220-240		1~ 220-240		1~ 220-240		1~ 220-240	
Frequency [Hz]	50	60	50	60	50	60	50	60
Power [W]	73	77	73	77	72	76	75	76
Current [A]	0,32	0,34	0,32	0,34	0,32	0,33	0,33	0,33
Max. air capacity [m³/h]	240	255	330	345	420	435	420	435
RPM [min⁻¹]	2560	2690	2590	2700	2600	2720	2690	2720
Noise level at 3 m [dBA]	33	34	35	36	36	37	36	37
Transported air temperature [°C]	-25 +55		-25 +55		-25 +55		-25 +55	
SEC class	C		C		C		C	
Protection rating	IP X4		IP X4		IP X4		IP X4	

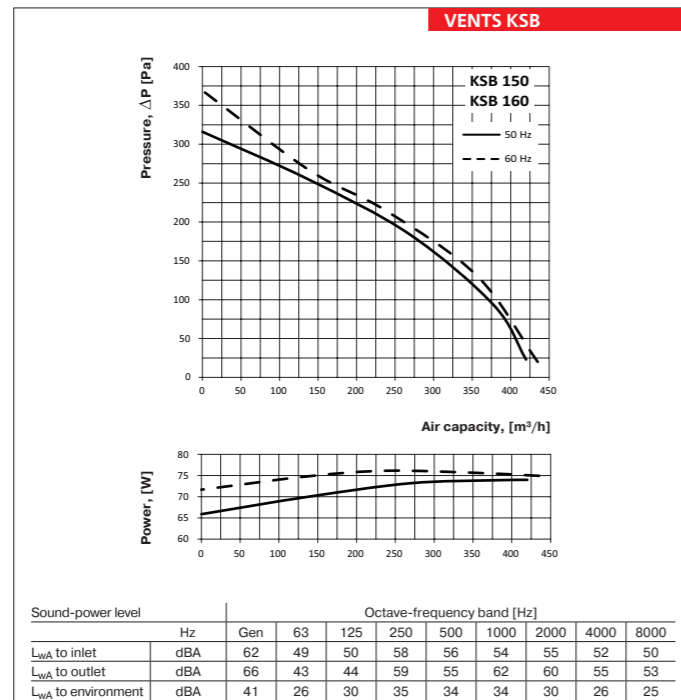
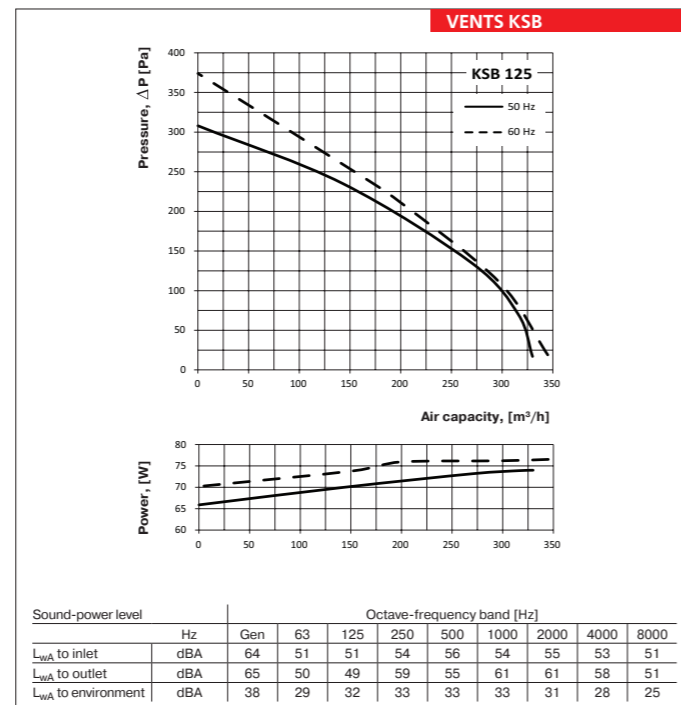
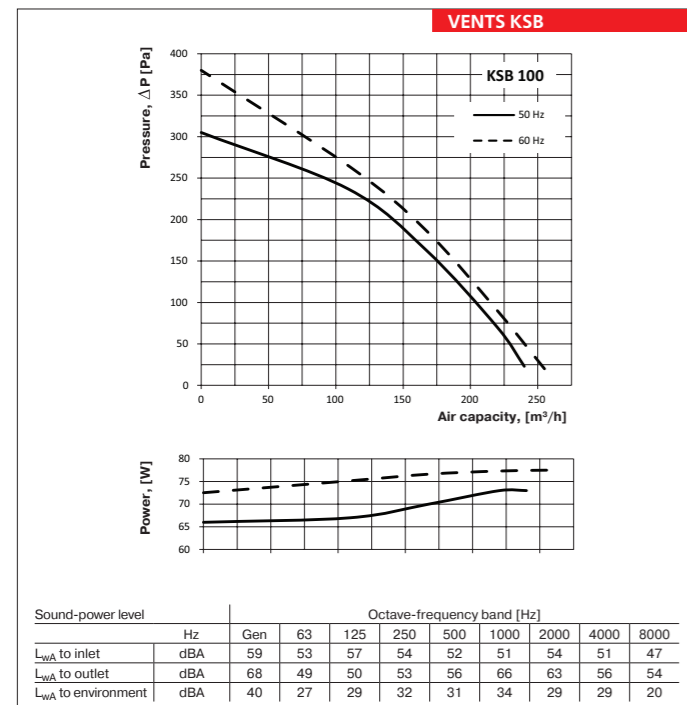

Technical data:

	KSB 200		KSB 200 S		KSB 250		KSB 315	
Voltage [V]	1~ 220-240		1~ 220-240		1~ 220-240		1~ 220-240	
Frequency [Hz]	50	60	50	60	50	60	50	60
Power [W]	103	122	195	232	198	238	322	367
Current [A]	0,45	0,53	0,85	1,02	0,87	1,04	1,4	1,6
Max. air capacity [m³/h]	730	750	950	960	1300	1315	2150	2150
RPM [min⁻¹]	2550	2740	2570	2690	2420	2730	2670	2850
Noise level at 3 m [dBA]	38	39	41	42	41	43	43	44
Transported air temperature [°C]	-25 +55		-25 +55		-25 +55		-25 +55	
SEC class	B		B		-		-	
Protection rating	IP X4		IP X4		IP X4		IP X4	

